

Winkhaus FGTE

Security French door locking system for timber and composite doors



in
Doors



Winkhaus FGTE

Security French door locking system for timber and composite doors



Key features:-

- Door construction techniques the same as traditional joinery methods used in laminated engineered timber.
- Lever operated Lock mechanism incorporating two heavy duty brass hooks, latch and deadbolt with two shootbolts on the slave leaf.
- Optional shootbolts on master door for tall doors.
- 25mm throw security hooks help counter bow and twist and aid the easy operation of the locking system.
- For a traditional appearance handles are fitted to both slave and master door.
- Slave and Master door have independent cylinder locking capability and can be keyed alike using Winkhaus's extensive range of cylinder options.
- Standard slave and Master backset option of 45mm or 55mm for optimum knuckle clearance.
- Heavy duty high security Shootbolts on slave leaf only (most effective PAS23/24 security configuration*).
- Shootbolts can be cropped to size to suit individual door leaf height.
- Fully adjustable centre latch striking plate +/- 2mm to prevent door edge damage.
- Hook clearance and compression adjustment +/- 2mm.
- Fully adjustable shootbolt keeps +/- 2mm.
- Slave door lock can be independently deadlocked via euro profile cylinder.
- Lever operated hook throw.
- Upper Security hook fitted in a lower position to allow for lower height double doors.
- Police 'Secured by Design' approved.
- Suitable for both inward and outward double doors.

* Winkhaus UKAS accredited independent Test Laboratory available in Kettering for either a low cost indicative test day or a full UKAS PAS23/24 endurance and Security test.

Technical details:-

- 20mm wide faceplate on both slave and master door locks for stability and ease of routing.
- Latch striker plate adjustment +/- 2mm.
- Hook and Shootbolt keep adjustment +/- 2mm.
- For production efficiency shootbolt keeps manufactured with radiused ends to allow CNC plunge routing.
- Hook and latch plate adjustment via easy to operate Torx T15 screwdriver bits.
- 8mm square tri-laminate Shootbolts with 20mm throw and support shoulders for optimum security.
- Extended latch striker prevents damage to door sash when door closing.
- Reversing mechanism on slave lock neatly fits into eurogroove eliminating excessive sash machining.
- 'Silver' Chrome 6 free corrosion resistant plating to Grade 4 BS EN 1670.
- Shootbolt options allow door rebate heights between 1820mm and 2759mm.
- Use optional Winkhaus FGTE Configurator to determine parts required.



The Winkhaus FGTE Configurator is available on request and is used to identify parts based on input variables (i.e. Handle Height, Rebate Height, Backset, Handing, etc.). Excel 2003 or newer required.



FGTE French door layout with slave shootbolts only

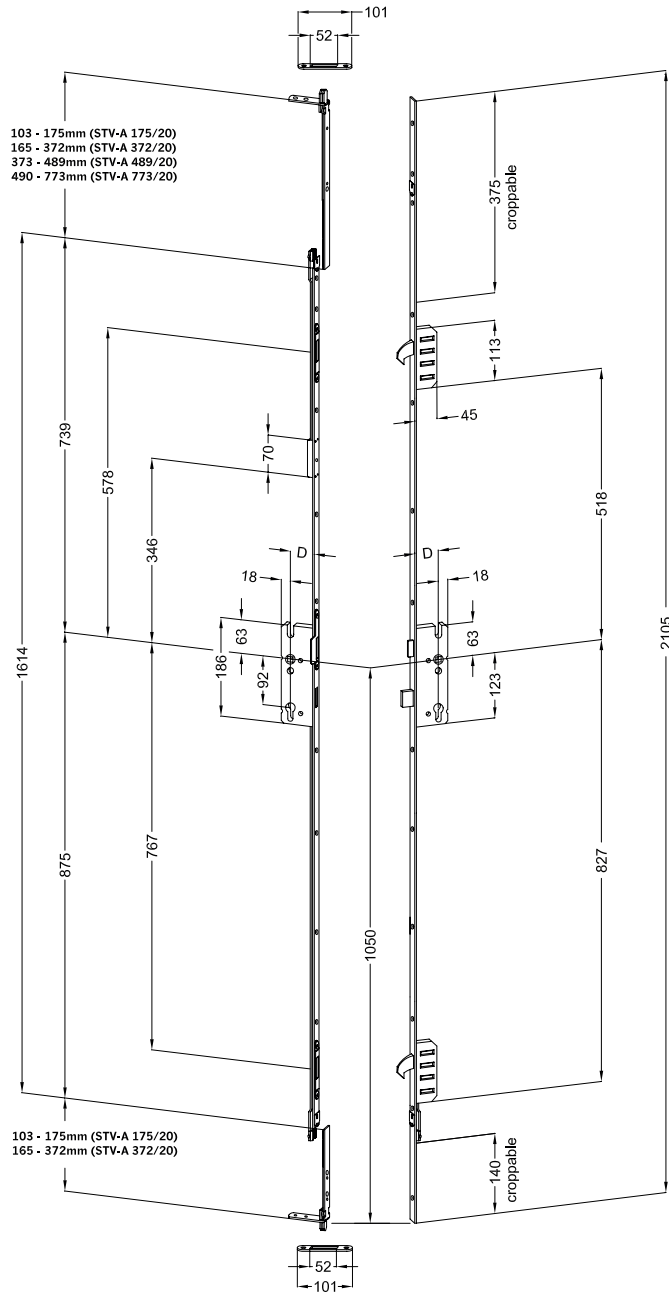

REBATE HEIGHTS

HANDLE HEIGHTS		Top Shootbolt STV-A 175/20	Top Shootbolt STV-A 372/20	Top Shootbolt STV-A 489/20	Top Shootbolt STV-A 773/20
		1040-1247mm VARIABLE	Bottom Shootbolt STV-A 372/20	1882mm ^A - 2161mm ^B	1944mm ^A - 2358mm ^B
978-1050mm VARIABLE	Bottom Shootbolt STV-A 175/20	1820mm ^A - 1964mm ^B	1882mm ^A - 2161mm ^B	2090mm ^A - 2278mm ^B	2207mm ^A - 2562mm ^B

PAS 24

A = Top and bottom shootbolts both fully cropped
B = Top and bottom shootbolts both non-cropped

FGTE French door layout with slave and master shootbolts

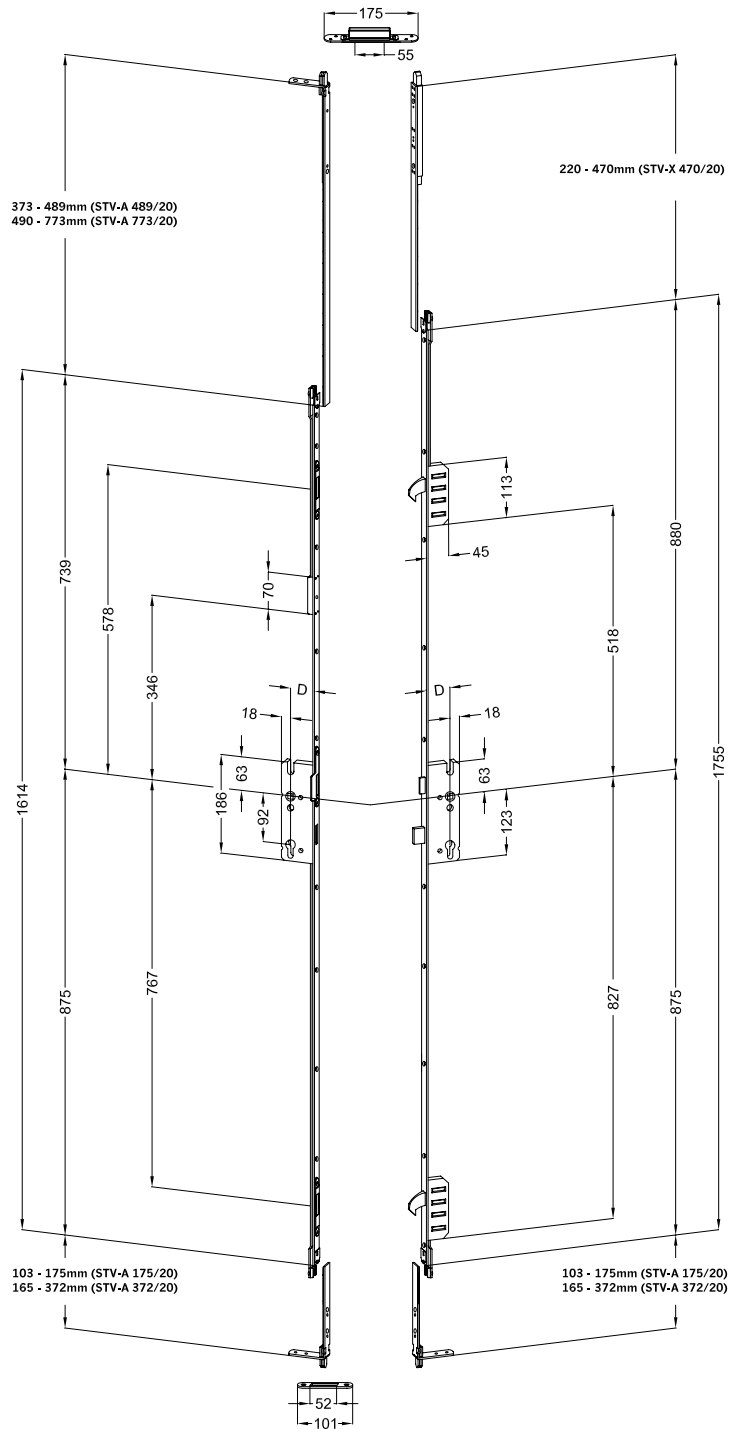

REBATE HEIGHTS

HANDLE HEIGHTS	REBATE HEIGHTS			
		Top Slave Shootbolt STV-A 372/20	Top Slave Shootbolt STV-A 489/20	Top Slave Shootbolt STV-A 773/20
1040-1247mm VARIABLE	Bottom Slave Shootbolt STV-A 372/20	2140mm ^A - 2358mm ^B	2152mm ^A - 2475mm ^B	2269mm ^A - 2597mm ^B
978-1050mm VARIABLE	Bottom Slave Shootbolt STV-A 175/20	2078mm ^A - 2161mm ^B	2090mm ^A - 2278mm ^B	2207mm ^A - 2400mm ^B

A = Top and bottom slave shootbolts both fully cropped
 B = Top and bottom slave shootbolts both non-cropped

Winkhaus FGTE French door locking system for timber and composite doors.

Winkhaus have developed a unique solution to the problem of bulky sight lines which can be prevalent with traditional timber French Doors but at the same time have been able to address the security challenges related to PAS23/24 Security testing.

After extensive development and testing the result is three options:-

Option 1 FGTE Locking System for rebated doors

A traditional design rebated french door incorporating a 45mm backset lock mechanism on both the master and slave doors. The hook locking points lock directly into the opposing slave door lock as does the central deadbolt and latch. This arrangement is ideally suited for door leaves up to 56mm thick.

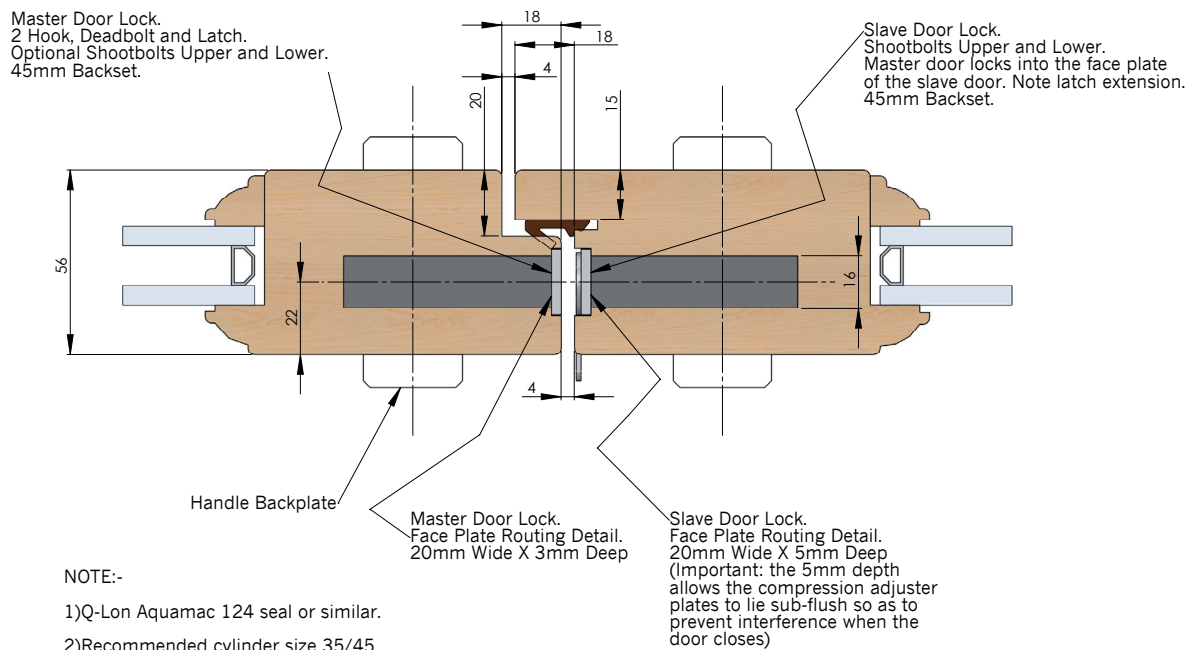

Option 2 FGTE Locking System for False mullion application

A traditional design french door incorporating a 45mm backset lock mechanism on the master door and a 55mm backset on the slave so that a balanced equidistant handle position is achieved.

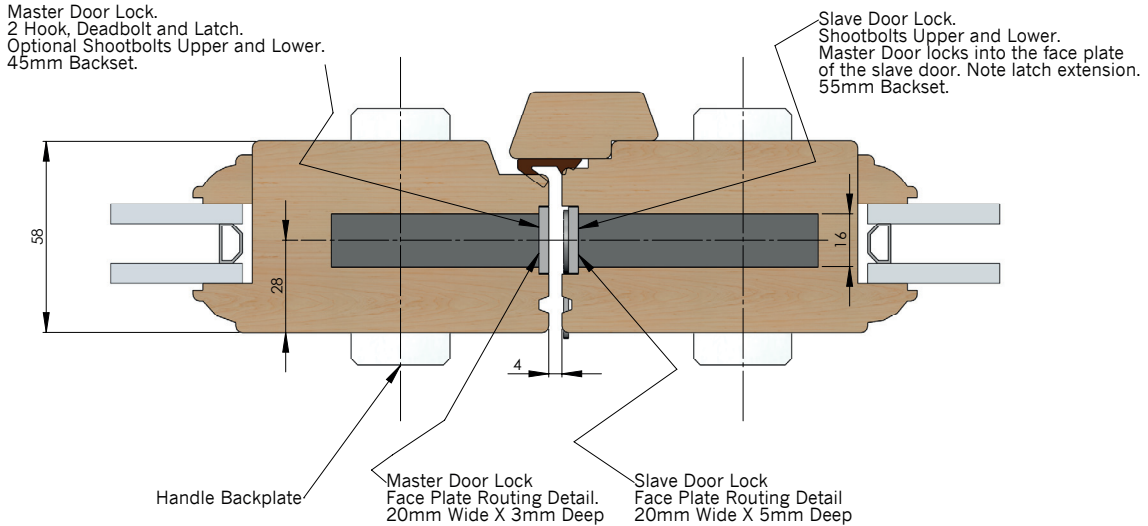

NOTE:-

- 1)Q-Lon Aquamac 124 seal or similar.
- 2)Recommended cylinder size 40/40.

Option 3 FGTE Locking System with Aluminium Meeting Stile Adaptors

Utilising the same lock mechanism but with a universal aluminium meeting stile on each leaf it cleverly adapts standard 44mm door slabs into a slim line French door set.

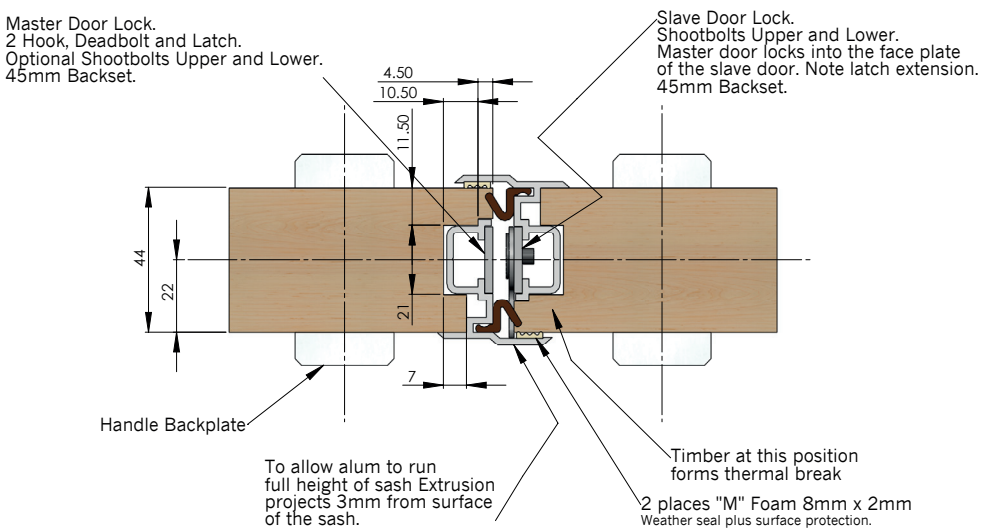

NOTE:-

- 1)Q-Lon Aquamac 21 seal or similar.
- 2)Recommended cylinder size 35/35.

Winkhaus UK Ltd

2950 Kettering Parkway, Kettering,
Northants NN15 6XZ

Tel: +44 (0)1536 316000

Fax: +44 (0)1536 416516

www.winkhaus.co.uk

email: enquiries@winkhaus.co.uk